

The entire amplifier/sensor assembly of an MF Series Melt Pressure Transmitter is packaged in a stainless steel welded enclosure with a conduit cable fitting. This metal enclosure is completely sealed from the atmosphere, and is approved to meet hazardous area requirements.

The MF converts applied pressure at the point of measurement to a proportional voltage output signal. An amplifier converts the strain gage signal to a 4-20 mA output. The small capillary tube filled with a special medium isolates the amplifier from potential thermal damage.

MAIN FEATURES

- Factory Mutual approved Explosionproof for Class I, Division 1, Groups A, B, C, D, and Dust-Ignitionproof for Class II, Division 1, Groups E, F, G
- Other approvals: CE, NEMA 4/IP65
- High-level output 2-wire, 4-20 mA
- Accuracy: $<\pm 0.25\%$ FSO (H); $<\pm 0.5\%$ FSO (M)
- Internally generated 80% calibration signal (R-Cal)
- 1/2-20 UNF thread standard, M18x1.5 also available
- Fluid-filled system for temperature stability
- 15-5 PH stainless steel diaphragm with Armoloy coating standard (others available on request)
- 17-7 PH corrugated diaphragm with TiN (Titanium Nitride) coating for ranges below 100 bar (1500 psi)

- MF0** The rigid stem configuration makes installation fast and easy.
- MF1** The flexible configuration is designed for applications requiring further thermal isolation or where installation would be otherwise difficult or impractical.
- MF2** The pressure/temperature configuration requires only one mounting hole for the measurement of both process values.



TECHNICAL SPECIFICATIONS

Nominal Accuracy including Linearity, Repeatability, Hysteresis	H $<\pm 0.25\%$ FSO for ranges 100 bar (1500 psi) and above M $<\pm 0.50\%$ FSO for ranges below 100 bar (1500 psi)
Resolution	Infinite
Measurement Range	0-35 to 0-2000 bar 0-500 to 0-30000psi
Maximum Overpressure below)	2 x FSO (1000 bar [15000 psi] an 1.5 x FSO (above 1000 bar [15000 psi])
Measurement Principle	Strain gage Wheatstone bridge
Supply Voltage	12-30 VDC (24 VDC rec.)
Maximum Current Consumption	20 mA
Isolation Resistance (at 50 VDC)	> 1000 M Ω
Full Scale Output (FSO)	20 mA
Zero Balance	4 mA
Signals Adjustment Nomina Pressure Ambient Pressure	5% FSO min. 10 bar (150 psi)
Response Time (10 to 90% FSO)	~ 8 ms
Output Noise (RMS 10-400 Hz)	< 0.05% FSO
Calibration Signal	80% FSO
Protection Against Output Short Circuit and Supply Voltage Inverted Polarity	YES
Protection Against Output Voltage Spikes	YES according to 89/336/EEC
Strain Gage Housing Compensated Temperature Range	0°C to 76°C (32°F to 170°F)
Housing Temperature Range	-30-85°C (-22-185°F)
Thermal Drift * in Zero shift Compensated RangeSensitivity shift	2.0%/100°C (1.0%/100°F) 2.0%/100°C (1.0%/100°F)
Maximum Diaphragm Temperature	400°C (750°F)
Maximum Zero Drift due to Change in Process Temperature	0.02 bar/°C (15 psi/100°F)
Material in contact with process medium	Standard 15-5PH SS (Armoloy coated) Below 100 bar (1500 psi) Corrugated 17-7PH SS (Titanium Nitride coated)

FSO = Full Scale Output (output signal at nominal pressure)

* For ranges below 70 bar [1000 psi], zero and sensitivity shift are 6.0%/100°C (3.0%/100°F)

MECHANICAL DIMENSIONS

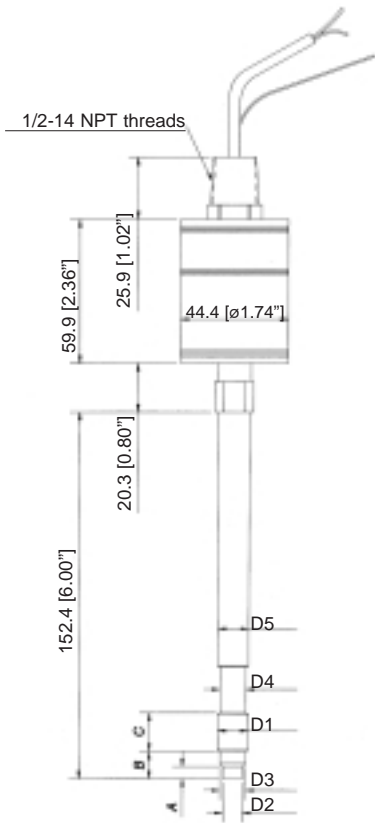

MF0

D1	1/2-20 UNF
D2	ø7.8 -0.05 [ø0.307" -0.002]
D3	ø10.49 ±0.025 [ø0.413" ±0.001]
D4	ø10.67 [ø0.42"]
D5	ø12.7 [ø0.5"]
A	5.56 -0.26 [0.219" -0.01]
B	11.4 [0.45"]
C	15.75 [0.62"]
Ch	16
[Hex]	[5/8"]

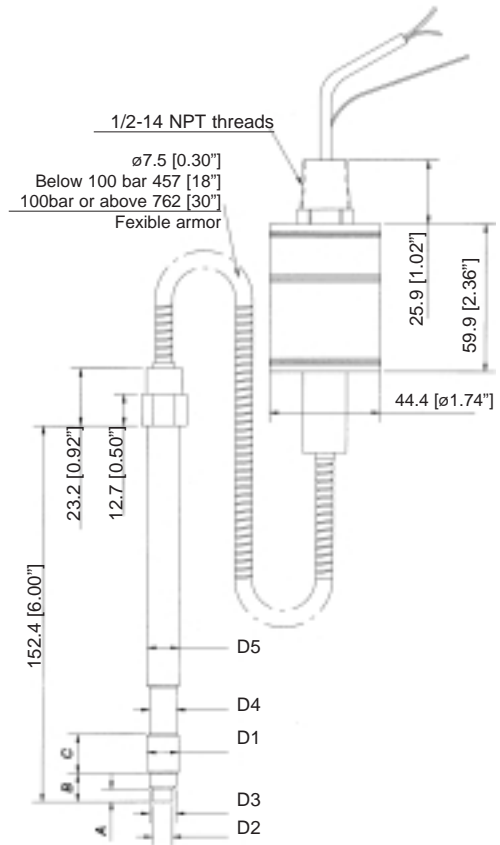

MF1

D1	M18x1.5
D2	ø10 -0.05 [ø0.394" -0.002]
D3	ø16 -0.08 [ø0.630" -0.015]
D4	ø16 -0.4 [ø0.630" -0.015]
D5	ø18 [ø0.71"]
A	6 -0.26 [0.236" -0.010]
B	14.8 -0.4 [0.580" -0.016]
C	19 [0.75"]
Ch	19
[Hex]	[3/4"]

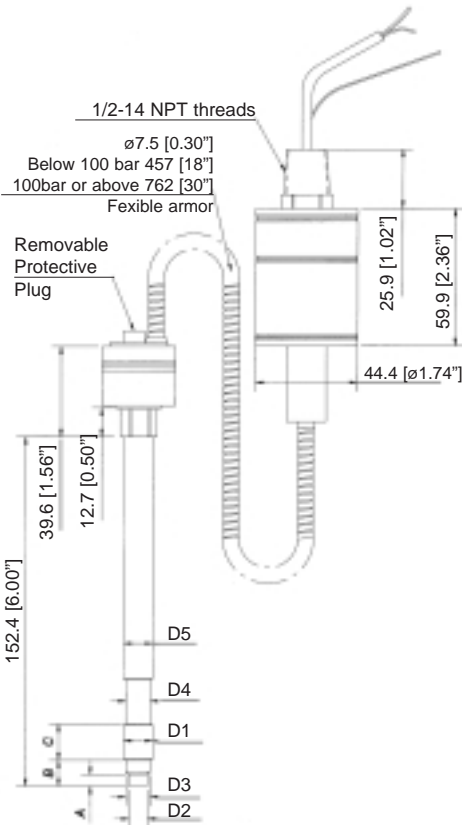

MF2

NOTE:

Dimensions refer to rigid stem length option "4" (153mm – 6") and flex length option "D" (457mm – 18")

WARNING:

For installation, use a maximum tightening torque of 56 Nm (500 in-lb)

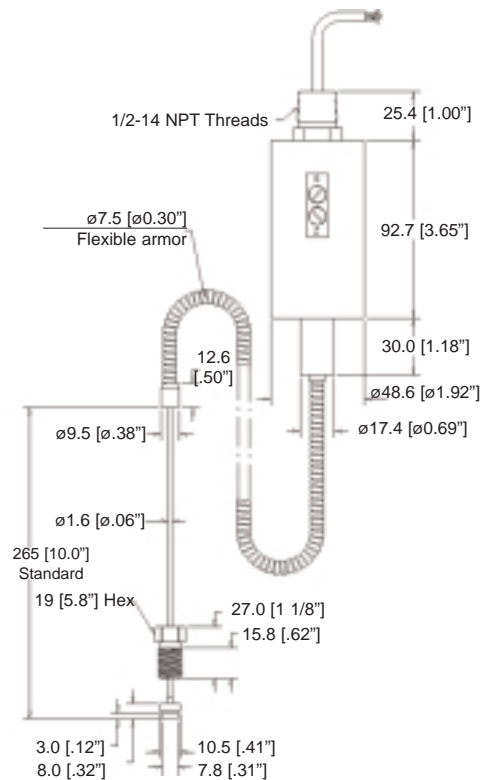

MF3

ELECTRICAL CONNECTIONS

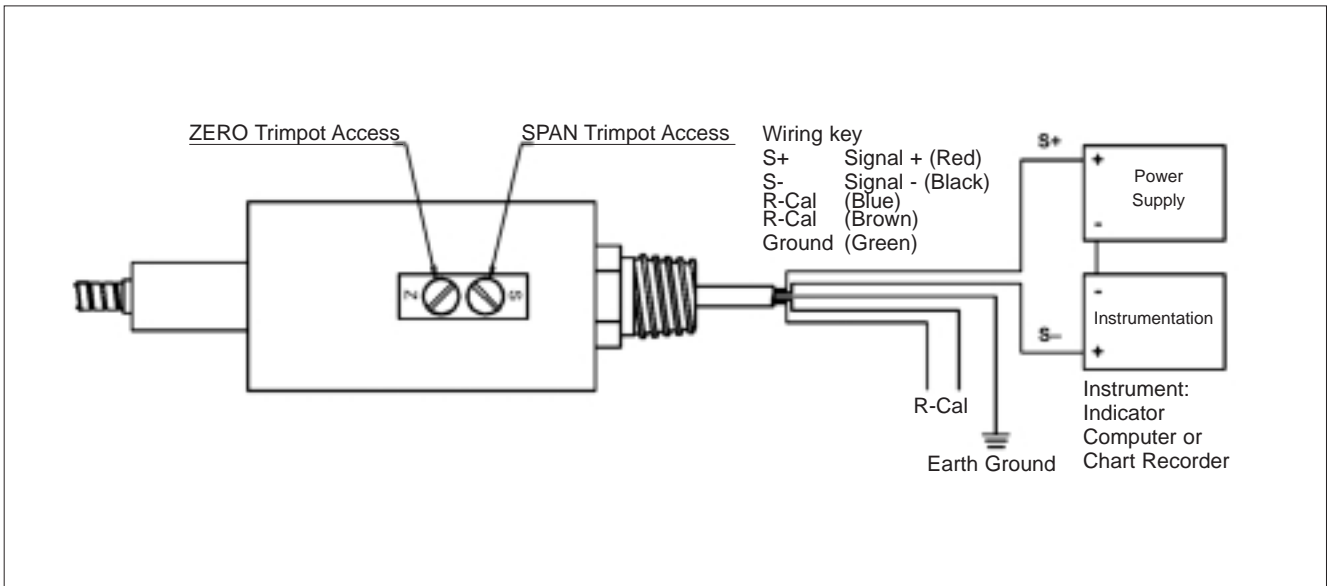

LOAD DIAGRAM FOR CURRENT OUTPUT

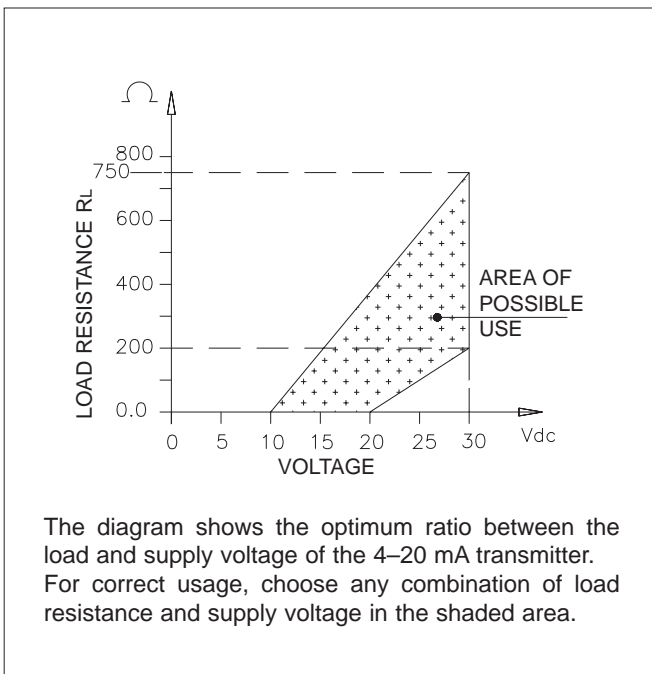

ADJUSTMENTS

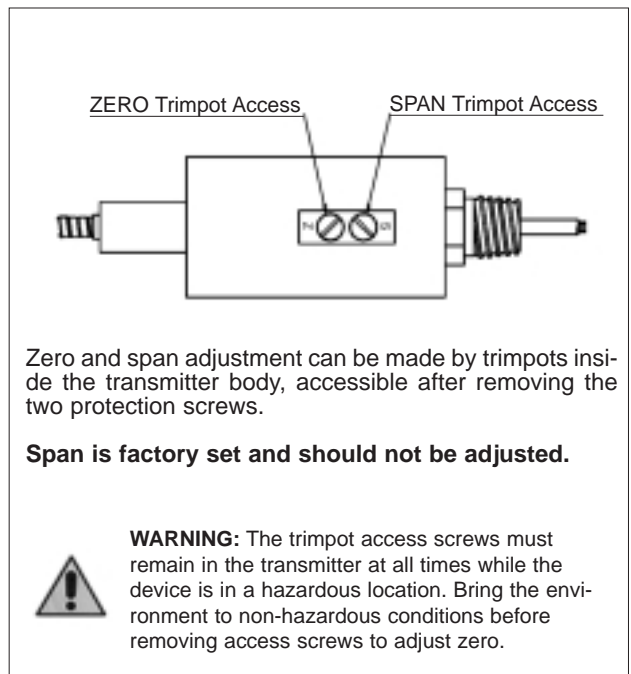

ACCESSORIES

Mounting bracket	SF18
Dummy plug for 1/2-20UNF	SC12
Dummy plug for M18x1.5	SC18
Drill kit for 1/2-20UNF	KF12
Drill kit for M18x1.5	KF18
Cleaning kit for 1/2-20UNF	CT12
Cleaning kit for M18x1.5	CT18

ORDER CODE

M|F - **N** - [] - [] - [] - [] - [] - **000**

OUTPUT SIGNAL	
4-20 mA Explosionproof	F

VERSION	
Rigid Stem	0
Rigid Stem + Flex	1
With Thermocouple	2
Exposed Capillary	3

CONNECTOR	
NPT	N

ACCURACY CLASS	
0.25% FSO (ranges \geq 100 bar/1500 psi)	H
0.50% FSO	M

RANGE			
bar		psi	
35	B35U	500	P05C
50	B05D	750	P75D
70	B07D	1000	P01M
100	B01C	1500	P15C
200	B02C	3000	P03M
350	B35D	5000	P05M
500	B05C	7500	P75C
700	B07C	10000	P10M
1000	B01M	15000	P15M
1400	B14C	20000	P20M
2000	B02M	30000	P30M

000 = standard version
Special or customized versions available on request

FLEXIBLE LENGTH (mm, inches)	
Standard (MF0)	
0	none
Standard (MF1, MF2)	
D	457 mm, 18"
E	610 mm, 24"
F	760 mm, 30"
Standard (MF3)	
L	711 mm, 28"
Available on request	
A	76 mm, 3"
B	153 mm, 6"
C	300 mm, 12"
G	914 mm, 36"
H	1067 mm, 42"
I	1220 mm, 48"
J	1372 mm, 54"
K	1520 mm, 60"

RIGID STEM LENGTH (mm, inches)	
Standard (MF0, MF1, MF2)	
4	153 mm, 6"
5	318 mm, 12.5"
Standard (MF3)	
0	none
Available on request	
1	38 mm, 1.5"
2	50 mm, 2"
3	76 mm, 3"
6	350 mm, 14"
7	400 mm, 16"
8	457 mm, 18"

THREAD	
Standard	
1	1/2-20 UNF
4	M18x1.5
Available on request	
2	M10x1.0
3	M14x1.5

Examples

MF2-N-H-B07C-1-4-D-000

Explosionproof melt pressure transmitter with thermocouple access, 1/2-20 UNF thread, 700 bar full scale output, 0.25% accuracy class, 153 mm (6") rigid stem, 457 mm (18") flexible armor

MF0-N-M-P01M-1-4-0-000

Explosionproof melt pressure transmitter, rigid stem, 1/2-20 UNF thread, 1000 psi full scale output, 0.50% accuracy class, 153 mm (6") rigid stem

GEFRAN reserves the right to make any kind of design or functional modification at any moment without prior notice.

GEFRAN spa
via Sebina, 74
25050 PROVAGLIO D'ISEO (BS) - ITALIA
tel. 0309888.1 - fax. 0309839063
Internet: <http://www.gefran.com>

GEFRAN

cod. MF0 - 12/05