



### Main features

- Range of measurement: from 500 to 5.000 Kg
- Accuracy class: D (OIML R60)
- All stainless steel construction
- Corrosion resistant
- Insensitive to lateral loads
- Low profile
- Class of protection: IP66 (DIN 40050)

The principle of measurement of the SB series of load cells is the deformation caused by the shear generated by the applied load. They are compact load cells with an all stainless steel construction that are extremely rigid towards the measured load and lateral or transverse loads.

The SB series load cells are the ideal solution for industrial weighing applications such as storage silos, weighing platforms and dosing systems.

### TECHNICAL DATA

Accuracy (OIML IR60)	D1
Divisions	1000
Nominal full scale load (Ln)	500...5.000 Kg
Nominal full scale output FSO	3mV/V
Output tolerance at Ln	< ± 0,2% FSO
Combined errors*: Non linearity Hysteresis, Repeatability	< ± 0,03% FSO
Creep (after 30 min. at Ln)	< ± 0,03% FSO
Zero load out of balance signal	< ± 0,5% FSO
Thermal drift in compensated range *	Sensitivity Zero Calibration < ± 0,005% FSO°C < ± 0,01% FSO°C -
Nominal input resistance	350 Ohm
Nominal output resistance	350 Ohm
Isolation resistance	> 10 GOhm
Nominal supply voltage	10 V
Maximum supply voltage	15 V
Compensated temperature range	-10...+40°C
Maximum temperature range	-20...+60°C
Storage temperature range	-30...+80°C
Permitted static load	130% Ln
Maximum applicable load	150% Ln
Rupture load	> 300% Ln
Maximum elastic deformation at Ln	< 0,6 mm
Grade of protection (DIN40050)	IP66
Electr. connections screened cable	4x0,25 / 5 m.
Elastic element material	Stainless steel

\* The combined error and sensitivity thermal drift as a whole are within the limits defined by the OIML IR60

### MECHANICAL DIMENSIONS

Hole version

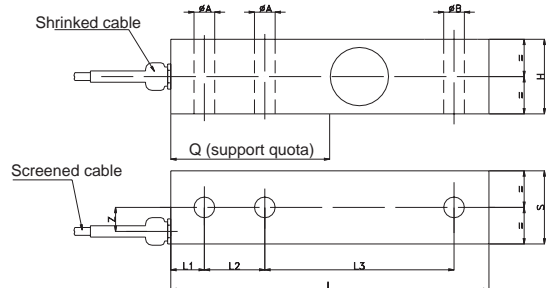

Thread hole version

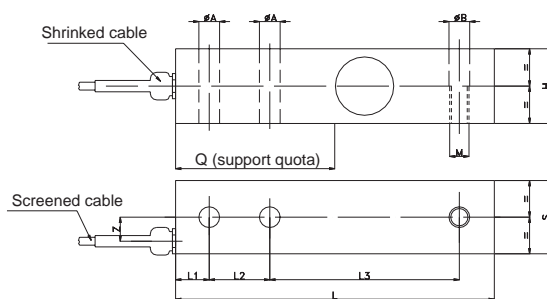

	Ln (Kg)	
	500/1000/2000	5000
∅ A	13,4	20,5
∅ B	13,4	20,5
M	M12	M18x1,5
H	31,75	47,6
S	31,75	38
L	130	171,5
L1	15,75	19,1
L2	25,4	38,1
L3	76,2	95,3
Z	9	11,5
Nm*	135	660
Q	60	75

Dimensions mm. (± 0,1)

\* Recommended torque with UNI 5931 screws of resistance class 10.9 according to UNI 3740

## ELECTRICAL CONNECTIONS

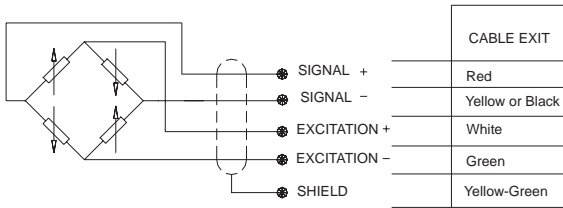

**4x0.25  
Screened cable**

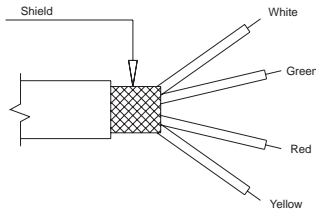

\* The screen is isolated from the transducer body. It is recommended that the ground is connected at the instrument end.

### Cells connected in parallel

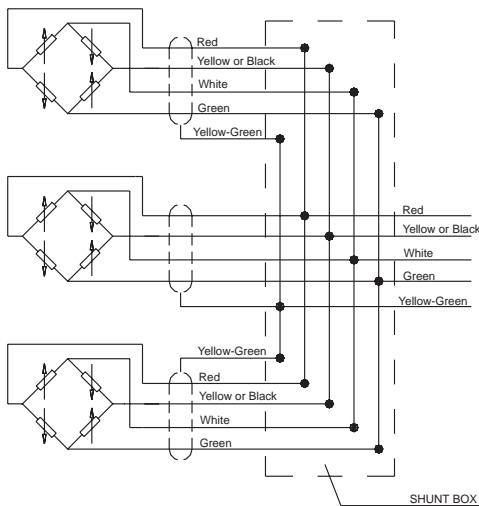

In systems that use several cells, the parallel connection automatically sums the loads on each individual cell.

Using this method of measurement, the maximum load will be the sum of the loads on the individual cells and the sensitivity will be the average value of these cells. It is important that the user ensures that no cell is stressed beyond its maximum rating under any load condition.

## CONVERSION TABLE

Kg	N	Lb
1	9.807	2.205
0.102	1	0.225
0.454	4.448	1

GEFRAN spa reserves the right to make any kind of design or functional modification at any moment without prior notice.

## OPTIONAL ACCESSORIES

### ORDER CODE

Load cell **SB**

#### MEASUREMENT RANGE (Kg)

0 - 500	<b>K5C</b>
0 - 1000	<b>K1M</b>
0 - 2000	<b>K2M</b>
0 - 5000	<b>K5M</b>

#### LOAD APPLICATION HOLE

Hole version *	<b>FP</b>
Thread hole version	<b>FF</b>

\* not available for 0...5.000 Kg version

If request, it is possible to supply models with non-standard mechanical and/or electrical features.

#### Ex1.: **SB - K1M - FP**

SB load cell, measurement range 0-1.000 kg.  
Load application hole without thread.

#### Ex2.: **SB - K1M - FF**

SB load cell, measurement range 0-1.000 kg.  
Load application hole with thread