



Main features

- Range of measurement: from 100 to 3000 kN
- Accuracy class: 0,5%
- Elastic element in stainless steel
- Corrosion resistant
- Internally generated calibration signal
- Grade of protection: IP65 (DIN 40050)

The CT series force transducers, have been specially designed for use in polymer processing in applications where it is required to measure the reaction force produced by the extrusion pressure on the gearbox along the axis of the screw. They measure a force whose value is indicative of the extrusion pressure over the area of the screw.

The CT series force transducers can also be used in all other applications where it is required to measure the forces on shafts or columns and in any application where the geometry demands a toroidal form load cell.

TECHNICAL DATA

Accuracy	0,5%
Nominal full scale load (Ln)	100...3000 kN
Nominal output at FSO	2mV/V
Output tolerance at Ln	<± 1% FSO
Combined errors: Non linearity Hysteresis, Repeatability	< ± 0,5% FSO
Creep (after 30 min. at Ln)	< ± 0,06% FSO
Zero load out of balance signal	< ± 1% FSO
Calibration signal *	80%FSO ± 1%
Thermal drift in compensated range	Sensitivity Zero Calibration
	< ± 0,02% FSO°C < ± 0,02% FSO°C < ± 0,02% FSO°C
Nominal input resistance	700 Ohm
Isolation resistance	> 10 GOhm
Nominal supply voltage	10 V
Maximum supply voltage	15 V
Compensated temperature range	-20...+50°C
Maximum temperature range	-20...+60°C
Storage temperature range	-30...+80°C
Permitted static load	130% Ln
Maximum applicable load	150% Ln
Rupture load	> 300% Ln
Maximum static lateral load	40% Ln
Maximum elastic deformation at Ln	< 0,1 mm
Grade of protection (DIN40050)	IP65
Electr. connections: Connector	VPT02A10-6PT2
Elastic element material	Stainless steel
Case material	Anodize aluminium
* The exact value is indicated on the instrument nameplate.	

MECHANICAL DIMENSIONS

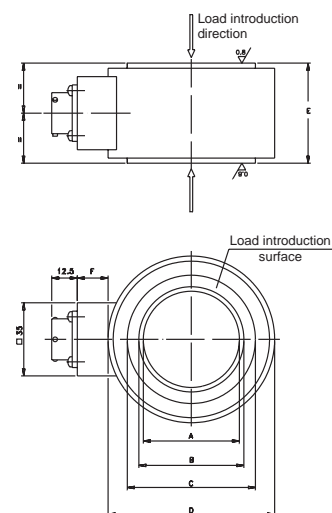

Dimensions mm. (± 0,1)

mod.	Ln (kN)	A	B	C	D	E	F
CTA	100		54,2	57,8			
	200	46	52,6	59,7	80	45	15
	300		50,7	61,4			
CTB	200		76,2	81,3			
	300		74,9	82,5			
	500	70	72,2	84,9	101	45	45
CTC	750		72	84,7			
	500		102,8	112,1			
	750		100,2	114,2			
CTD	1000	94	97,9	116,5	140	60	45
	1500		95,3	118,6			
	1500		124,1	146,2			
CTD	2000		120,1	149,6			
	2500	110	115,8	152,9	196	60	80
	3000		111,4	156			

ELECTRICAL CONNECTIONS

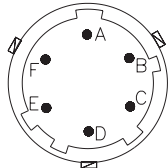
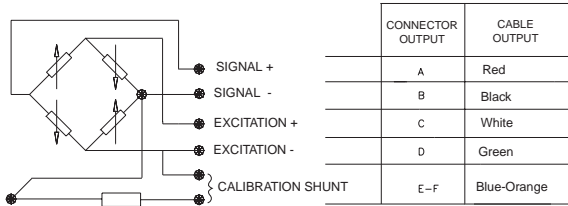

CONNECTOR
VPT02A10-6PT2

If the transducer is supplied complete with prewired connection cable, the colour code is that indicated in the table.

Cells connected in parallel

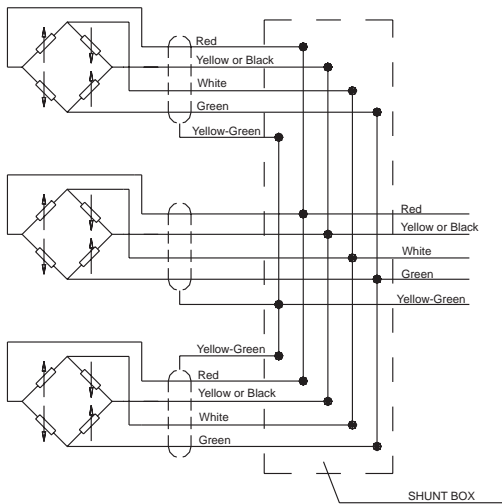

In systems that use several cells, the parallel connection automatically sums the loads on each individual cell.

Using this method of measurement, the maximum load will be the sum of the loads on the individual cells and the sensitivity will be the average value of these cells. It is important that the user ensures that no cell is stressed beyond its maximum rating under any load condition.

CONVERSION TABLE

Kg	N	Lb
1	9.807	2.205
0.102	1	0.225
0.454	4.448	1

OPTIONAL ACCESSORIES

Connectors

Female cable connector
Grade of protection IP65

CON300

6-pin connector with 8m (25ft) cable
6-pin connector with 15m (50ft) cable
6-pin connector with 25m (75ft) cable
6-pin connector with 30m (100ft) cable

C08W

C15W

C25W

C30W

Other lengths

**consult
factory**

APPLICATION NOTE

For a correct use of the transducer, it is necessary to ensure that the load is evenly distributed over the application surfaces shown in the diagram.

It is essential to centre the transducer using the circular crown of diameter **C** and to apply the load installing the transducer between two grinded surfaces perpendicular to the direction of the applied load.

ORDER CODE

Force transducer **CT**

MODEL

A

B

C

D

Mod.	MEASUR. RANGE (kN)	
CTA	0-100	KN1C
	0-200	KN2C
	0-300	KN3C
CTB	0-200	KN2C
	0-300	KN3C
	0-500	KN5C
	0-750	KN7.5C
CTC	0-500	KN5C
	0-750	KN7,5C
	0-1000	KN1M
	0-1500	KN1.5M
CTD	0-1500	KN1.5M
	0-2000	KN2M
	0-2500	KN2.5M
	0-3000	KN3M

If request, it is possible to supply models with non-standard mechanical and/or electrical features.

Ex.: CTC - KN1M

CT force transducer, model C, measurement range 0 - 1000 kN.

GEFRAN spa reserves the right to make any kind of design or functional modification at any moment without prior notice.

GEFRAN spa

via Sebina, 74

25050 PROVAGLIO D'ISEO (BS) - ITALIA

ph. 0309888.1 - fax. 0309839063

Internet: <http://www.gefran.com>

www.gefranonline.com

GEFRAN

cod. CT - 09/04