



Main features

- Range of measurement: from 100 to 50.000 Kg
- Accuracy class: 0,1%
- All stainless steel construction
- Corrosion resistant
- Internally generated calibration signal
- Grade of protection: IP67 (DIN 40050)

CM series load cells are strain gauge transducers used to measure loads in static and dynamic applications, in compression, with high accuracy. They are machined from a single block of metal, so the primary sensing element, the mountings and the case contain no welds allowing smaller dimensions and an enhanced grade of protection. The configuration of the point of measurement, with 8 strain gauges, reduces errors caused by imperfect applications of the load. Typical applications of load cells connected in parallel are: silos, hoppers, large weighing platforms. The stainless steel construction is suitable for use in aggressive environments in the chemical and petrochemical industries.

TECHNICAL DATA

Accuracy	0,1%
Nominal full scale load (Ln)	100...50.000 Kg
Nominal output at FSO	2mV/V
Output tolerance at Ln	<± 0,2% FSO
Combined errors: Non linearity Hysteresis, Repeatability	< ± 0,1% FSO
Creep (after 30 min. at Ln)	< ± 0,06% FSO
Zero load out of balance signal	< ± 1% FSO
Calibration signal *	80%FSO ± 1%
Thermal drift in compensated range	Sensitivity Zero Calibration
	< ± 0,01% FSO°C < ± 0,01% FSO°C < ± 0,01% FSO°C
Nominal input resistance	700 Ohm
Nominal output resistance	700 Ohm
Isolation resistance	> 10 GOhm
Nominal supply voltage	10 V
Maximum supply voltage	15 V
Compensated temperature range	-10...+50°C
Maximum temperature range	-20...+60°C
Storage temperature range	-30...+80°C
Permitted static load	130% Ln
Permitted dynamic load	100% Ln
Maximum applicable load	150% Ln
Rupture load	> 300% Ln
Maximum elastic deformation at Ln	< 0,2 mm
Grade of protection (DIN40050)	Cable: IP67 Connector: IP65
Electr. connections: Connector Screened cable	VPT02A10-6PT2 6x0,25 / 5 m.
Elastic element material	Stainless steel

* The exact value is indicated on the instrument nameplate

MECHANICAL DIMENSIONS

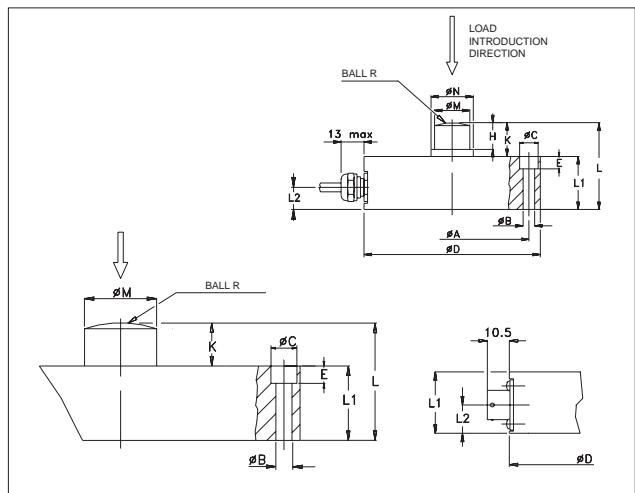

	Ln (Kg)			
	100 2000	3500 7000	10000 30000	50000
ø A	87	98,5	102,2	125
ø B	6,5	10,5	13	17
ø C	10,5	16,5	19	25
ø D	100	120	126	155
E	6	10	12,5	16,5
H	11,7	17,5	-	-
K	15,7	21,5	14	16
L	45,7	51,5	54	77
L1	30	30	40	61
L2	13,5	13,5	17	27
ø M	20	24	35	45
ø N	24	30	-	-
R	30	30	50	100
VITI	6XM6	6XM6	6XM12	6XM16
Nm*	9	60	100	200

Dimensions mm. (± 0,1) * Recommended torque with UNI 5931 screws of resistance class 10.9 according to UNI 3740.

ELECTRICAL CONNECTIONS

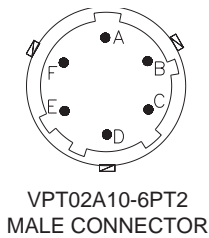
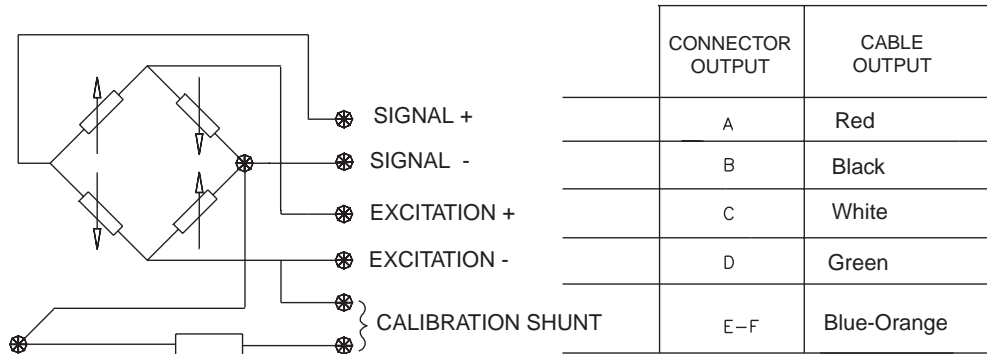

If the transducer is supplied complete with prewired connection cable, the colour code is that indicated in the table.

6x0.25 Screened cable

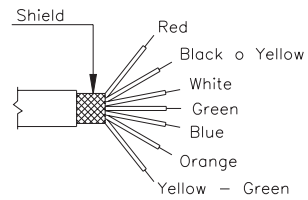

* The screen is isolated from the transducer body.
It is recommended that the ground is connected at the instrument end.

Cells connected in parallel

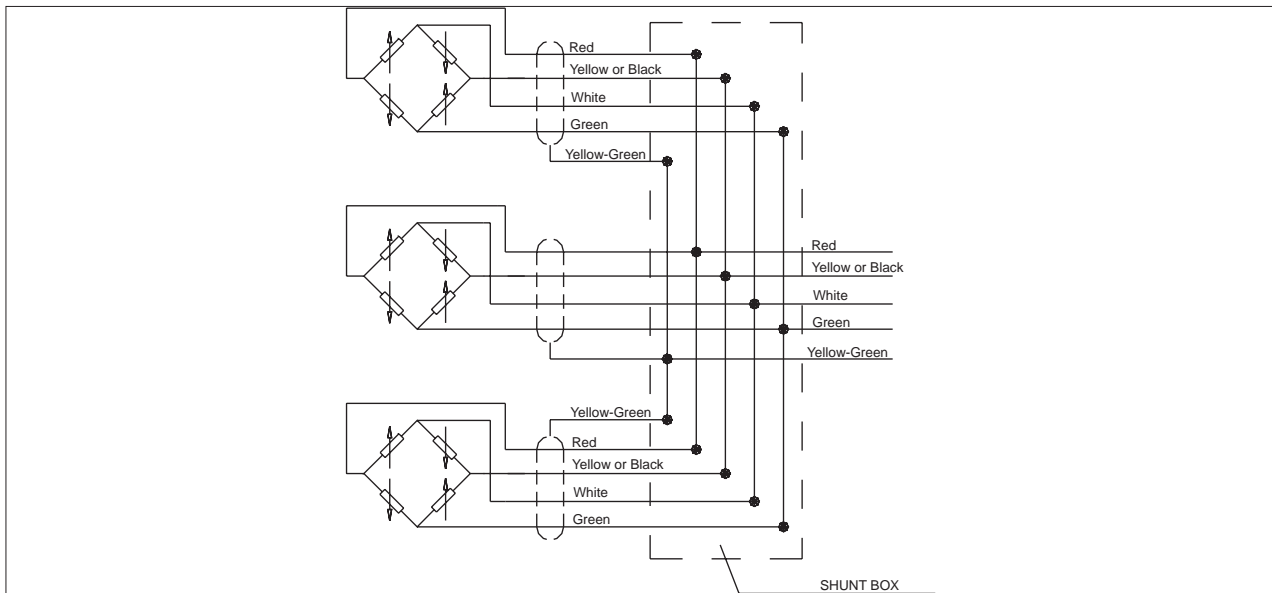

In systems that use several cells, the parallel connection automatically sums the loads on each individual cell. Using this method of measurement, the maximum load will be the sum of the loads on the individual cells and the sensitivity will be the average value of these cells.

It is important that the user ensures that no cell is stressed beyond its maximum rating under any load condition.

CONVERSION TABLE

Kg	N	Lb
1	9.807	2.205
0.102	1	0.225
0.454	4.448	1

OPTIONAL ACCESSORIES

Female cable connector Grade of protection IP65

6-pin connector with 8m (25ft) cable

6-pin connector with 15m (50ft) cable

6-pin connector with 25m (75ft) cable

6-pin connector with 30m (100ft) cable

Other lengths

Self alignment plate

(Max. inclination 3°)

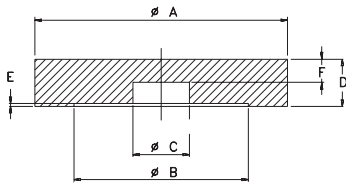

NOMINAL LOAD Kg				
	≤ 2000	≤ 7000	≤ 30000	≤ 50000
∅ A	100	120	126	155
∅ B	74	100	105	130
∅ C	24	28	37	47
D	20	25	32	50
F	11	12	22	39
E	1,25	1,5	2	3
COD	PIA700	PIA701	PIA702	PIA703

Dimensions mm. (± 0,1)

CON 300

C08W

C15W

C25W

C30W

consult factory

Cable colour code	
Conn.	wires
A	Red
B	Black
C	White
D	Green
E	Blue
F	Orange

ORDER CODE

Load cell

CM

MEASUREMENT RANGE (Kg)	
0 - 100	K1C
0 - 200	K2C
0 - 350	K3.5C
0 - 500	K5C
0 - 700	K7C
0 - 1000	K1M
0 - 2000	K2M
0 - 3500	K3.5M
0 - 5000	K5M
0 - 7000	K7M
0 - 10000	K10M
0 - 20000	K20M
0 - 30000	K30M
0 - 50000	K50M

ELECTRICAL CONNECTIONS	
6x0,25 5m screened cable	F
VPT02A10-6PT2 connector	C

If request, it is possible to supply models with non-standard mechanical and/or electrical features.

SENSITIVITY	
S	2mV/V version
R	3mV/V version (range 500...5000Kg) only

Ex.: **CM - K10M - F - S**

CM load cell, range 0 - 10.000 kg, cable connection and 2mV/V standard sensitivity.

GEFRAN spa reserves the right to make any kind of design or functional modification at any moment without prior notice.

GEFRAN

GEFRAN spa
 via Sebina, 74
 25050 PROVAGLIO D'ISEO (BS) - ITALIA
 ph. 0309888.1 - fax. 0309839063
 Internet: <http://www.gefran.com>
www.gefranonline.com

cod. CM - 09/04