

GEFRAN

PZ67-A

RECTILINEAR DISPLACEMENT TRANSDUCER
WITH IP67 PROTECTION LEVEL



Main features

- This transducer is designed to guarantee a high protection level (IP67) in applications under harsh conditions and outdoors, where it may be necessary to work in the direct presence of dust, dirt, or liquids (not in prolonged immersion)
- Its high protection level and very small size make the PZ67-A unique in terms of reliability and flexible installation
- It is ideal for glass cutting and washing machines or for honers and sanders if there is direct exposure to liquids or even just steam
- Indicated for test and bench equipment, especially if outdoors

TECHNICAL DATA

Useful electrical stroke C.E.U.	10/25/50/75/100/125/150/175/200/250/300
Independent linearity (within C.E.U.)	see table
Resolution	infinite
Repeatability	0.01mm
Electrical connection	M8x1 3-pole connector
Protection level	IP67 (use M8x1 3-pole female connector with IP67 or higher protection level)
Life (NOT used in prolonged immersion)	> 25x10 ⁶ m strokes, or > 100x10 ⁶ maneuvers, whichever is less (within C.E.U.)
Displacement speed	Standard ≤ 3 m/s max ≤ 5 m/s
Displacement force	≤ 20N
Vibrations	5...2000Hz, Amax =0,75 mm amax. = 20 g
Shock	50 g, 11ms.
Acceleration	200 m/s ² max (20g)
Tolleranza sulla resistenza	± 20%
Recommended cursor current	< 0.1 μA
Maximum cursor current	10mA
Maximum applicable voltage	see table
Electric isolation	>100MΩ at 500V=, 1bar, 2s
Dielectric strength	< 100 μA at 500V~, .50Hz, 2s, 1bar
Dissipation at 40°C (0W a 120°C)	3W
Thermal coefficient of resistance	-200...+ 200 ppm/°C typical
Actual Temperature Coefficient of the output voltage	≤ 5ppm/°C typical
Working temperature	-30...+100°C
Storage temperature	-50...+120°C
Case material	Anodised aluminium
Control rod material	C45 Chrome steel 20μm
Mounting	Self-aligning joints with adjustable distance between centers

MECHANICAL DIMENSIONS

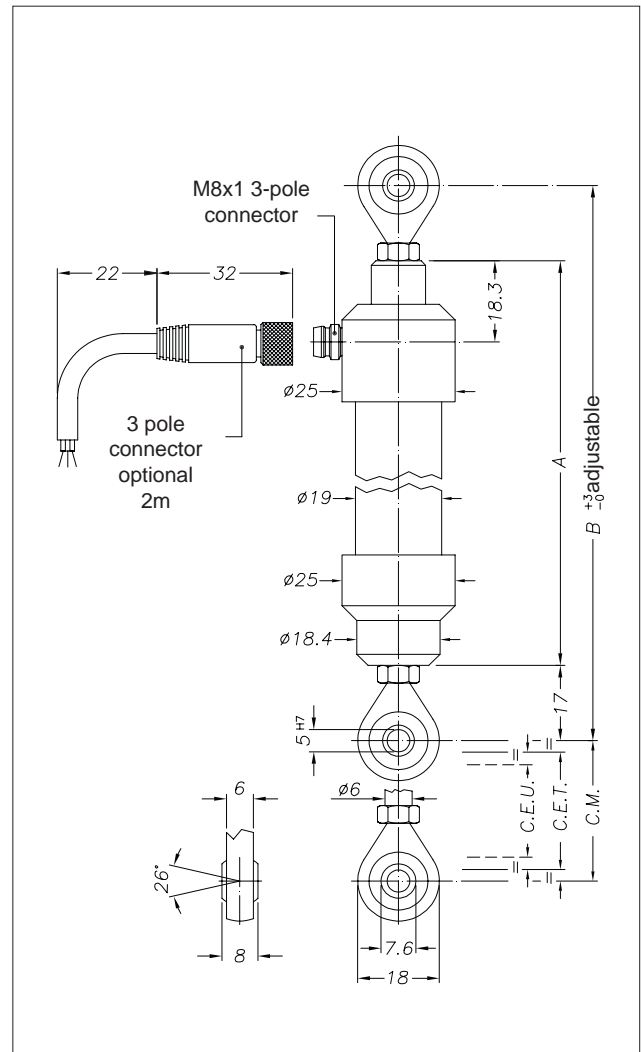

Important: all the data reported in the catalogue linearity, lifetime, temperature coefficient are valid for a sensor utilization as a ratiometric device with a max current across the cursor $I_c \leq 0.1 \mu A$

MECHANICAL / ELECTRICAL DATA

MODEL		10	25	50	75	100	125	150	175	200	250	300
Useful electrical stroke (C.E.U.) +1 / -0	mm	10	25	50	75	100	125	150	175	200	250	300
Theoretical electrical stroke (C.E.T.) ± 1	mm	C.E.U. +1										
Resistance (sulla C.E.T.)	kΩ	1	1	2	3	4	5	6	7	8	10	12
Independent linearity (within C.E.U.)	± %	0,5	0,2	0,1	0,1	0,1	0,05	0,05	0,05	0,05	0,05	0,05
Dissipation at 40°C (0W at 120°C)	W	0,3	0,8	1,6	2,6	8						
Maximum applicable voltage	V	15	20	40	60							
Mechanical stroke (C.M.)	mm	C.E.U. +5										
Case length (A)	mm	113,5	128,5	153,5	178,5	203,5	228,5	253,5	278,5	303,5	353,5	403,5
Recommended distance between brackets (B)	mm	148	163	188	213	238	263	288	313	338	388	438

ELECTRICAL CONNECTIONS

Connector output optional

- brown
- black
- blue

INSTALLATION INSTRUCTIONS

- Make the specified electrical connections (DO NOT use the transducer as a variable resistance)
- When calibrating the transducer, be careful to set the stroke so that the output does not drop below 1% or rise above 99% of the voltage level.

ORDER CODE

Displacement transducer **PZ67-A**

Model

No certificate attached	0
Linearity curve to be attached	L

				X				X		
--	--	--	--	---	--	--	--	---	--	--

Example.: **PZ67-A - 075 0000X000X00**
 Model PZ67-A displacement transducer, M8x1 3-pole connector output, useful electrical stroke (C.E.U.) 75mm., no certificate attached.

ACCESSORIES (on request)

Female connector + 2 meter cable in wired PVC	Code CAV010
---	------------------------------

GEFRAN spa reserves the right to make any kind of design or functional modification at any moment without prior notice