



Main applications

- Gate motors
- Conveyor belt motors

Main features

- Solid state contactor for forward/reverse control for 3-phase motors up to 4 KW – 400 VAC.
- Nominal voltage max.: 400Vac
- Non-repetitive voltage up to 900 Vp
- Input control: 5...32 VDC
- Isolation (input/output) 4000 VAC
- IP20 direct contact protection
- LED indication of motor direction
- Integrated voltage transient protection

PROFILE

The controller is a thyristor-type power solid state relay designed to control a 3-phase asynchronous motor in two directions.

There are two control signals and an internal logic that permits selection of only one direction at a time.

A green LED indicates forward; a red LED indicates reverse.

The power thyristors are protected against excessive voltage fluctuation by varistors and RC snubbers incorporated in the module.

It is advisable to install three high-speed fuses between the 3-phase line and the controller.

WARNING: The GI models must be used in conjunction with an appropriate heatsink (Accessory).

Installation must precisely observe the warnings contained in the installation notes.

TECHNICAL DATA

General features

Category of use: AC53a

Nominal voltage (Ue):

400Vac (max. range 24...440Vac)

Nominal frequency: 50/60Hz

Peak voltage: 900Vp

Critical dV/dt OFF-state:

500V/μs

I_{2t} for fusion t = 20 ms: 1120 A²s

Leakage current OFF:

max 5 mA @ 380Vac

Activation time (max.): 20ms

Deactivation time (max.): 60ms

Inversion time: 100ms

Potential drop at rated current: ≤ 1,4Vrms

IP20 protection

Control input

Voltage of command circuit (Uc):

5...32Vdc

Activation voltage: >4.5Vdc

Deactivation voltage: <3Vdc

Max. reverse voltage: - 40 Vdc

Max. input: 21 mA @ 5 Vdc

Max. input: 29 mA @ 32 Vdc

Output

Output motor

Nominal current (Imax):

AC53a: 3x6 A

Insulation

Nominal insulation voltage to ground
2500Vac

Nominal voltage from control and output:
4000Vac

Ambiental condition

• Working temperature:

-20°C...50°C

• Max. relative humidity:

50% a 40°C

• Max. installation altitude: 1000 slm

• Pollution level : 3

• Storage temperature:

-20...85°C

• Class: A (industrial device)

Thermal features

Junction time: ≤ 125°C

R_{th} junction/housing = 1.5 K/W

Solid Sate Relay Dissipated Power Calculation

Three-phase relay

P_d = 2 x 1,6 x IRMS [W]

IRMS = three-phase load current

Heatsink Thermal Resistance

Calculation

R_{th} = (90°C - T.amb.max) / P_d

P_d = dissipated power

T.amb.max = max air temperature inside the electrical cabinet.

Use a heatsink with thermal resistance inferior to the calculated one (R_{th})

Installation notes

Use the high speed fuses specified in the catalog according to the connection example provided.

Applications with solid state power units must also include an automatic safety switch to cut out the load power line.

Protect the solid state relay by using an appropriate heat sink (accessory).

The heat sink must be sized according to room temperature and load current (see the technical documentation).

Procedure for mounting on heat sink:

The module-heat sink contact surface must have a maximum planarity error of 0.05mm. and maximum roughness of 0.02mm. The fastening holes on the heat sink must be threaded and countersunk.

Spread 4 gram of thermoconductive silicone (we recommend DOW CORNING 340 HeatSink) on the dissipative metal surface of the module. The surfaces must be clean and there must be no impurities in the thermoconductive paste.

Use 4 M4x10 or M5 x 10 screws with flexible washer for attachment. Alternately tighten the fastening screws until reaching a torque of 0.60Nm.

Wait 30 minutes for any excess paste to

drain. Alternately tighten the four fastening screws until reaching a torque of 1.2 Nm for the M4 screws and 1.5 Nm for the M5 screws.

It is advisable to make random checks of correct installation by disassembling the module and checking that there are no air bubbles under the copper plate. Install the units cantilevered to the panel so that air can flow vertically over the heatsink without obstructions.

Limits of use

- dissipation of thermal power of device with restrictions on temperature of installation site.
- requires exchange with outside air or an air conditioner to transfer dissipated power outside the panel.
- max. voltage limits and derivative of transients in line, for which the solid state unit has internal protection devices.
- presence of dispersion current < 10mA (max. value with rated voltage and junction temperature of 125°C).

FACEPLATE DESCRIPTION

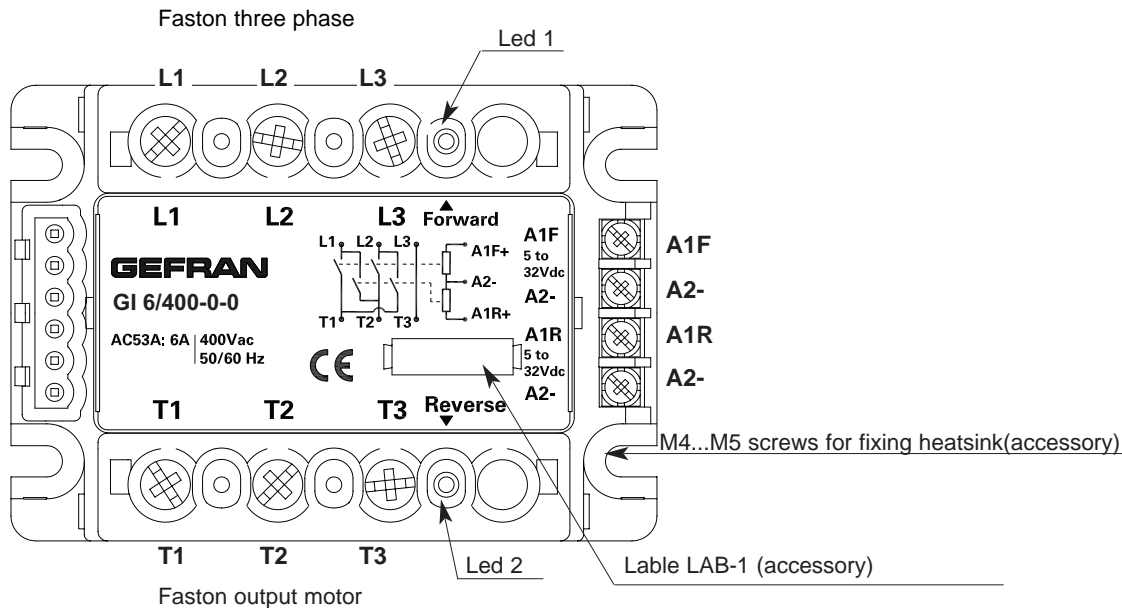

- L1 : Phase 1 input
- L2 : Phase 2 input
- L3 : Phase 3 input
- T1 : Phase 1 output (Motor)
- T2 : Phase 2 output (Motor)
- T3 : Phase 3 output (Motor)
- A1F : Forward run control (+5...32Vdc)
- A1R : Reverse run control (+5...32Vdc)
- A2- : GND run control
- Led1: Green LED indicates forward run ON
- Led2: Red LED indicates reverse run ON

DIMENSIONS

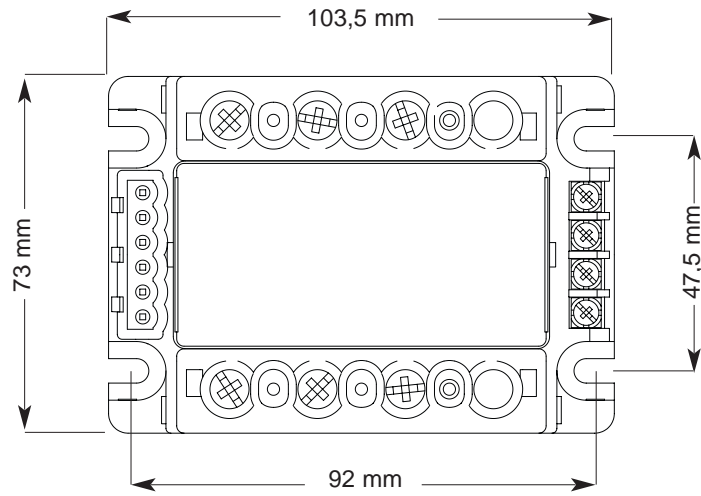

Depth = 43,5 mm
Weight = 300g

TYPE OF OPERATION

Voltage logic output control

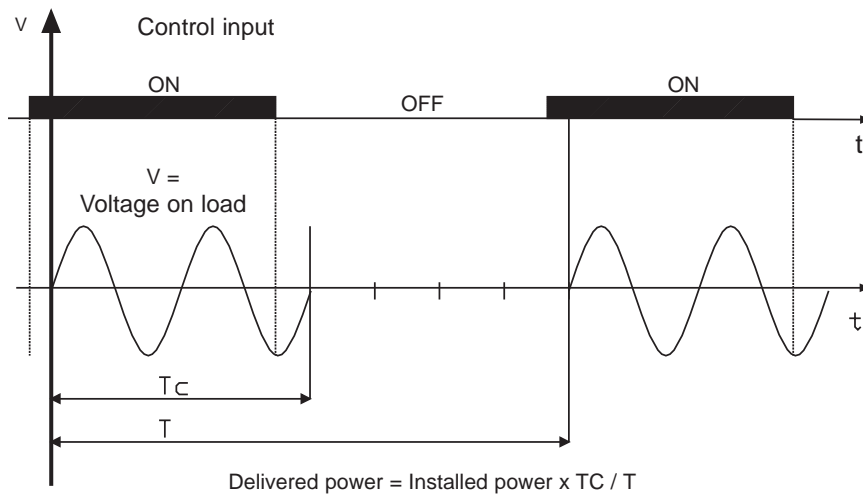

CONNECTION EXAMPLES

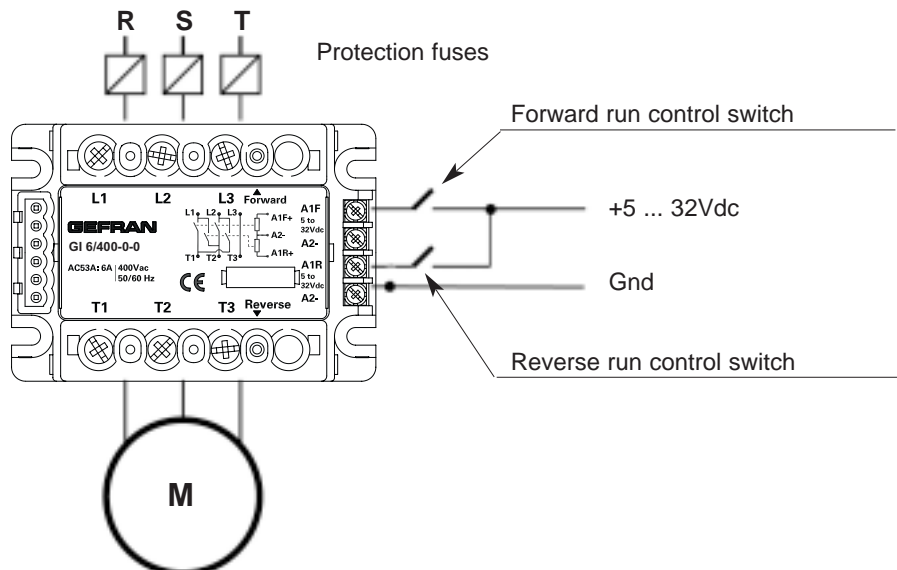

TABLE OF TERMINALS AND CONDUCTORS

Model	Control terminal (A1F, A2-, A1R, A2-)			Power terminal (L1, L2, L3, T1, T2, T3)		
	Contact area (LxP) screw type	Type of preinsulated terminal	Section. * conductor / tightening torque	Contact area (LxP) screw type	Type of preinsulated terminal	Section. * conductor / tightening torque
6A	6,3x9 M3	eye / fork / tip	min. 0.35 mm ² max. 2,5 mm ² 0,6 Nm Max	12x12 M5	occhiello / forcella / puntale	min. 1 mm ² max. 10 mm ² (tip)# min. 1 mm ² max. 16 mm ² (eye/fork) 1,5 - 2,2 Nm

(*) The max. sections specified refer to unipolar copper wires isolated in PVC.

Note: For the ground terminal, you have to use an eye wire terminal.

(LxP) = width x depth [mm]

The minimum acceptable nominal section based on the nominal currents of the power solid state units is given below for copper conductors isolated in PVC, under continuous operating conditions and at 40°C ambient temperature according to standards CEI 44-5, CEI 17-11, IEC 408 in accordance with EN60204-1.

Nominal current	Nominal section cable on mm ²
10A	2,5

Terminal covers

If an eye terminal lug is used, the terminal covers can be removed more easily by inserting a Phillips screwdriver (max. width 3.5 mm) into the side slots.

With the point of the screwdriver, widen the side of the cover and raise it.

Insert the screwdriver to facilitate opening of the cover

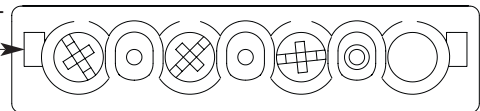

PROTECTION FUSES

Only high-speed fuses with $I^2t < 1000 \text{ A}^2\text{s}$ must be used to protect the module.

Choose a fuse current rating that can sustain surge currents when the motor starts.

Available fuses:

Ord. Code	Code	Rating	I ² t
338476	FUS-010	10 A (10x38mm)	70 A ² s
338470	FUS-016	16 A (10x38mm)	150 A ² s
338474	FUS-025	25 A (10x38mm)	390 A ² s
338483	FUS-032	32 A (10x38mm)	600 A ² s

Available fuse holders

Ord. Code	Code	Size
337132	PF-10x38	10x38 mm

EXAMPLE:

Motor: 1.5 KW – 380 V, I_n = 3.5A, the fuse rating is calculated by multiplying rated current by 5, using FUS-025.

REGULATORY REFERENCES

EMC Emission

CEI EN 60947-4-3	Emissions conducted at radio frequency	Class A (Industrial devices)
CEI EN 60947-4-3	Emission irradiated at radio frequency	Class A (Industrial devices)

EMC Immunity

IEC 61000-4-2	Electrostatic discharges	4kV per contact; 8 kV in air. Performance criterion 2.
IEC 61000-4-6	Electromagnetic radio frequency field 0,15-80MHz	Test level 3. Performance criterion 1
IEC 61000-4-3	Electromagnetic radio frequency field 80-1000MHz	Test level 10V/m. Performance criterion 1.
IEC 61000-4-4	Immunity to bursts	Test level 2kV/5 KHz. Performance criterion 2.
IEC 61000-4-5	Immunity to surges	Test level 2kV (Phase-ground); 1kV (Phase-phase). Performance criterion 2.

Security

CEI EN 61010-1	Safety norms
----------------	--------------

ORDER CODE

GI 6 / 400 - 0 - 0

GEFRAN spa reserves the right to make any kind of design or functional modification at any moment without prior notice

•WARNINGS

WARNING: this symbol indicates danger.

Read the following warnings before installing, connecting or using the device:

if the solid state relay is used in applications with risk of injury to people, machines, or materials, auxiliary alarm devices **MUST** be employed. It is also advisable to be able to check for tripping of alarms during normal operation;

- follow instructions precisely when connecting the heatsink;
- always use cables that are suitable for the voltage and current levels indicated in the technical specifications;
- **DO NOT** operate the device in rooms with dangerous (inflammable or explosive) atmosphere;
- During continuous operation, the heat sink can reach up to 100°C, and stays at a high temperature even after the device is turned off due to thermal inertia; therefore, **DO NOT** touch it and avoid contact with electrical wires;
- do not work on the power part without first disconnecting electrical power to the panel;
- do not remove the cover when the device is powered!

Installation:

- ground the heatsink connected to the power module;
- power supply lines must be separated from device input and output lines; always check that the supply voltage matches the voltage indicated on the device label;
- avoid dust, humidity, corrosive gases and heat sources;
- respect the installation distances between one device and another (to allow for dissipation of generated heat).
- to keep air in movement, we advise you to install a fan near the GZ group in the electrical panel containing the GZs.;
- size the heatsink adequately according to the indicated parameters.

Maintenance:

- at regular intervals, check operation of the cooling fans and clean all air ventilation filters;
- repairs must be done out only by trained and specialized personnel. Cut power to the device before accessing internal parts.
- do not clean the box with solvents derived from hydrocarbons (trichloroethylene, gasoline, etc.). Using such solvents will compromise the device's mechanical reliability. Use a clean cloth moistened with ethyl alcohol or water to clean external parts in plastic.

Service :

GEFRAN has a service department.

The warranty excludes defects caused by any use not conforming to these instructions.



This device conforms to European Union Directive 89/336/CEE and 73/23/CEE as amended with reference to product: **CEI-EN 60947-4-3** (Low voltage switchgear and controlgear - Contactors and Motor-starters)